

DRY & ADIABATIC CLOSED CIRCUIT COOLERS

eco-Air™ Series

environmentally
Conscious
Operation

Providing *Maximum* Water Savings

FEATURING



for LIFE





EVAPCO is more than a name.

It's a pledge to make everyday life easier, more comfortable, more reliable, and more sustainable for people everywhere. How do we fulfill that promise? It's simple.

We never stop innovating.

At EVAPCO, we don't just talk about innovation, it's ingrained in our workflow. Guided by our annually developed R&D plans, we set out to find groundbreaking solutions that transform the way the world works for the better. It's why we have more than 78 active patents worldwide.

We craft exceptionally built solutions.

As an employee-owned company, we take pride in our work. We are proud to be one of the most experienced teams of engineers and craftsmen in the industry. This translates into solutions that are always exceptionally built. EVAPCO has an unwavering commitment to provide "best in class" heat transfer solutions and services.

We guarantee performance.

Every EVAPCO solution is put through rigorous research and testing to ensure maximum efficiency and reliability. But we don't stop there. EVAPCO is an industry leader in independent, third-party performance certifications. These certifications guarantee our performance metrics—so that you can plan your projects with complete peace of mind.

We protect the environment.

Innovation and environmental sustainability go hand-in-hand at EVAPCO. Our industrial heat transfer equipment not only conserves natural resources and helps reduce noise pollution, but also features recycled steel content in construction. EVAPCO's stainless steel units are constructed of panels that contain up to 75% of recycled content, and our galvanized units contain over 80%. From sound reduction to water conservation to chemical elimination, we are continuously developing new technologies that deliver the ultimate operating advantages to our clients—while protecting the planet for every generation to come.

Get to Know EVAPCO

- The global innovator in heat transfer solutions
- Serving the commercial HVAC, Industrial Refrigeration, Power Generation, and Industrial Processing markets
- Founded in 1976
- Employee-owned
- 23 engineering & manufacturing facilities in 10 countries
- More than 170 sales offices worldwide

Learn More Now

Visit evapco.com to download product catalogs, view complete product specifications, and more.



FULL SPECTRUM GLOBAL SOLUTIONS



EVAPCO provides a full spectrum of global product solutions for the Commercial HVAC, Process Cooling, Industrial Refrigeration and Power Generation markets.

From the smallest factory assembled cooling tower to the largest field erected air-cooled steam condenser, we offer heat transfer products designed to meet the water and energy requirements for any project. We are committed to providing solutions that are energy efficient and conserve water.

Our latest heat transfer solutions are the eco-Air™ Series Dry Coolers, eco-Air Series Air Cooled Condensers, and eco-Air Series Adiabatic Coolers and Condensers. The eco-Air Series completes our successful eco-family of closed circuit coolers and condensers with water-saving dry and hybrid technology.

As an industry leader in independent, third-party performance certifications, our fully-rated products enable you to operate your cooling systems efficiently and with complete peace of mind.

The eco-Air Series of dry and adiabatic coolers offers unparalleled flexibility in a wide range of capacities, footprints, motor types, and control options.



EC Motor Option



NEMA Motor Option



EC Motor Option



NEMA Motor Option

EAWVA V Coil Adiabatic Models

EAWWD V Coil Dry Models



EC Motor Option



NEMA Motor Option

EAFWD Flat Coil Dry Models

eco-Air Series Design & Construction Features

The eco-Air Series of dry coolers represents EVAPCO's newest advancement in thermal heat transfer research and development. Available in fully dry and adiabatic designs, the eco-Air Series maximizes heat rejection with minimal or no water use. The eco-Air Series is another chapter in EVAPCO's ongoing commitment to high quality, environmentally friendly products.

Heat Exchanger Coil

- Type 304L Stainless Steel tubes with aluminum fins
- Multiple fin spacings and tube configurations
- Upgraded fin thickness available



Structure and Casing

- Standard Type 304L Stainless Steel for increased corrosion resistance and longevity
- G-235 galvanized steel available

Warranty

- 2 year complete unit
- 2 year Adiabatic Pads (if equipped)
- 1 year EVAPCO Controller and other electrical components (if equipped)



V Coil Models

- Maximum surface area per footprint
- Optimized coil angle for heat rejection and air flow
- Compact plan area and layout

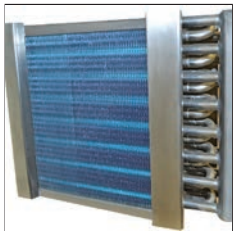

Epoxy Coated Fins (Optional)

- Increased corrosion resistance
- No impact on unit capacity



Inspection Panel (V Coil Models)

- Easily removable for interior inspection and access to coils and fan motors

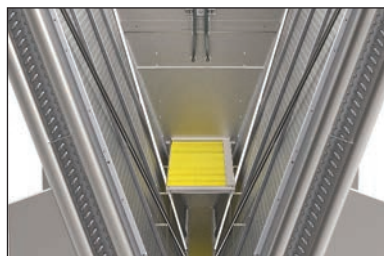

Internal Step Deck (Optional)

- Platform and grab rail for access to elevated fan section components
- V coil models only

Adiabatic Pre-Cooling System (Optional)

- Wetted pads can be utilized to pre-cool entering air, resulting in greater energy savings, and increased capacity, with minimal water use
- Great for high dry bulb climates and high temperature applications
- Once through design
- No water treatment required
- No cold water basin or pump
- No drift
- V coil models only

eco-Air Series Design & Construction Features

Advanced Motor Technology

Electronically Commutated (EC) or NEMA fan motor designs

NEMA

- Premium efficient direct drive
- Zero maintenance sealed bearings
- VFD ready
- Severe Duty



Electronically Commutated (EC)

EC motors are the latest development in energy savings and speed control. The high efficiency wing tip fans operate up to 3 dB less than conventional blade fans with improved part speed energy consumption.

- Zero maintenance
- Integrated speed control



Flat Coil Models

- Low profile design
- Great for elevated installations with bottom airflow clearance

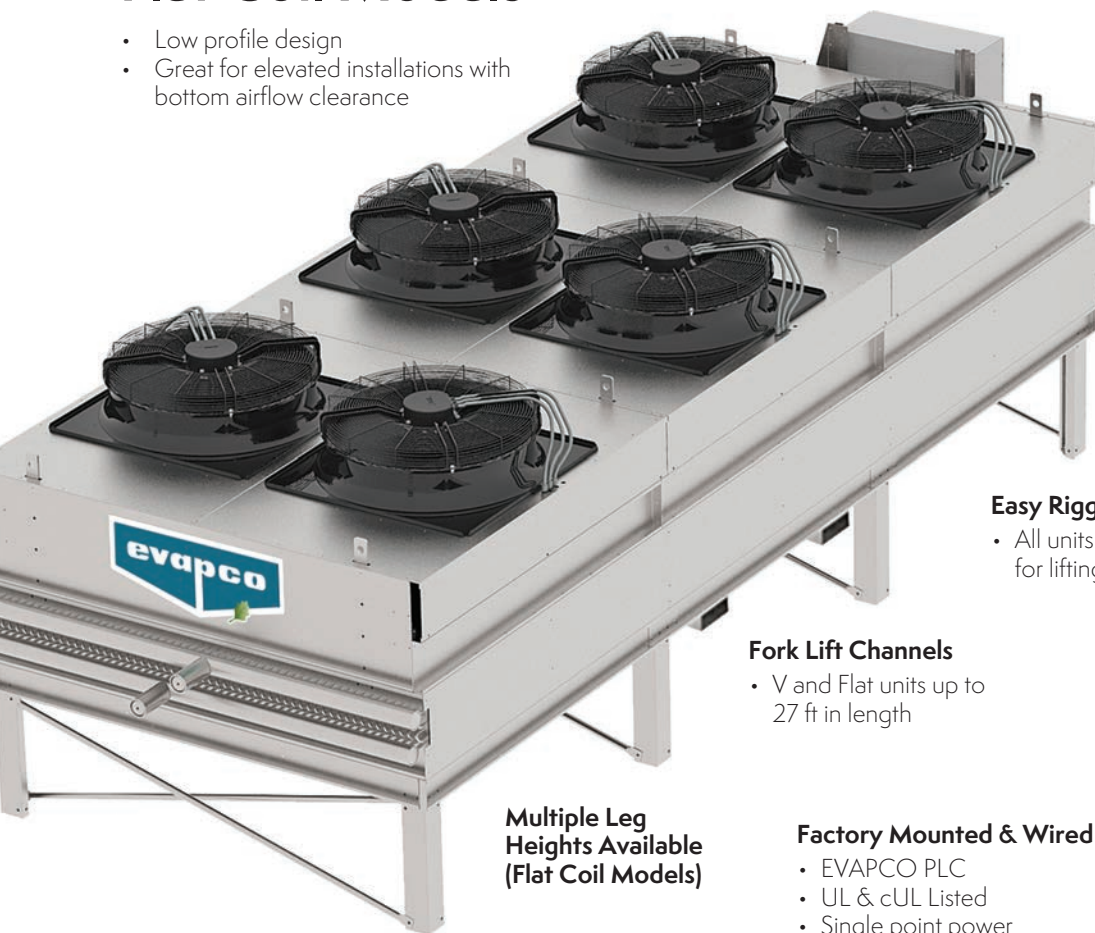

Coil Return Bend Covers

- Protects the coil return bends during handling and operation



Easy Rigging

- All units are designed for lifting as once piece

Fork Lift Channels

- V and Flat units up to 27 ft in length

Coils Pressurized with Nitrogen

- Limits internal corrosion potential during transport and storage

Multiple Leg Heights Available (Flat Coil Models)

Factory Mounted & Wired Controls (Optional)

- EVAPCO PLC
- UL & cUL Listed
- Single point power connection



Common Terminal Box

- All motors factory wired
- Saves time in the field
- UL Recognized



IBC Compliant Design

- All standard models meet IBC requirements
- Upgraded designs available for high seismic and wind load areas
- Shake table verified for 1.5 Importance Factor installations

Dry Principle of Operation

eco-Air Series V Coil (EAVWD) & Flat Coil (EAFWD) Air Cooled Cooler

Hot Process fluid enters the inlet header connection, shown in red. Heat from the fluid dissipates through the coil tubes surface and out to the fins. Ambient air is drawn in over the coil surface by the fan located at the top of the unit. Heat from the process fluid transfers to the air and discharges to the atmosphere. Cool process fluid exits the unit through the connections shown in blue.

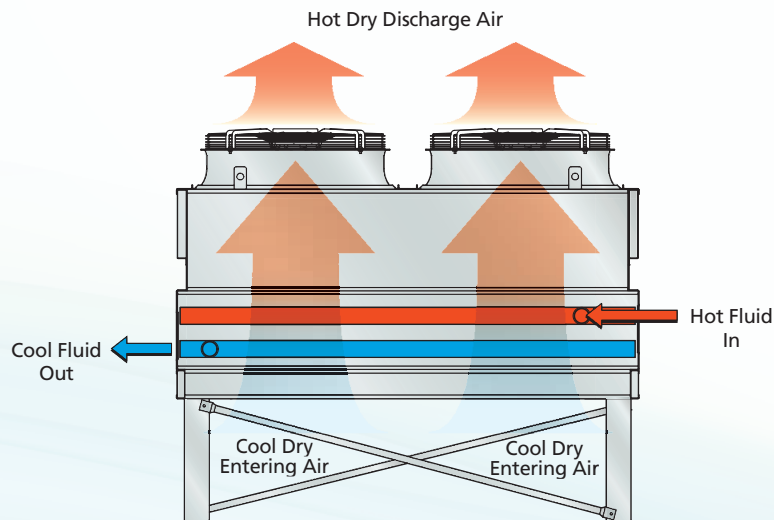
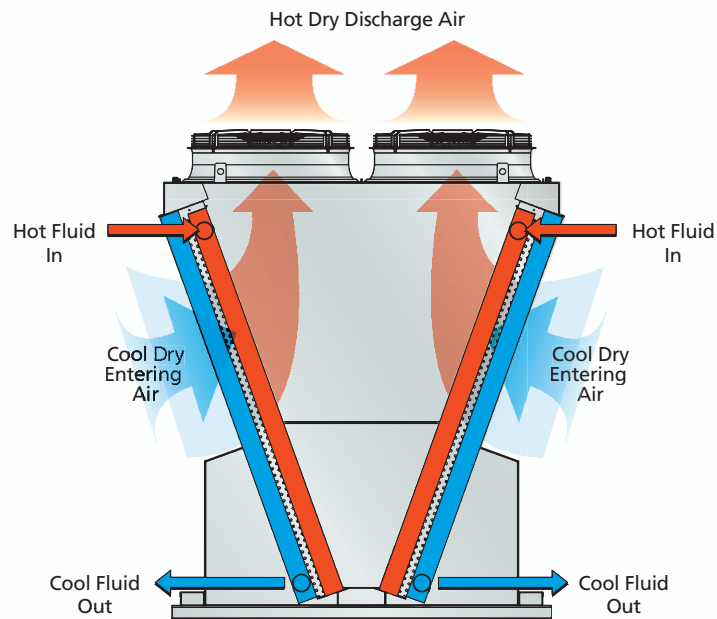

Adiabatic Principle of Operation

eco-Air Series V Coil (EAVWA) Adiabatic Cooler

Hot process fluid enters the inlet header connection, shown in red. Heat from the process fluid dissipates through the coil tubes surface and out to the fins. The adiabatic system involves fully wetting a fibrous pad located in front of the coil. Ambient air is drawn through the adiabatic pre-cooling pad by the fans located on top of the unit. The air is saturated as it passes through the adiabatic pad, decreasing the dry bulb temperature within a few degrees of the wet bulb temperature. This new air temperature is referred to as the depressed dry bulb. This pre-cooled air is then drawn through the tube and fin surface, offering a substantial increase in heat rejection capability. Heat from the process fluid transfers to the air and discharged to the atmosphere. Cool process fluid exits the unit through the connections shown in blue.

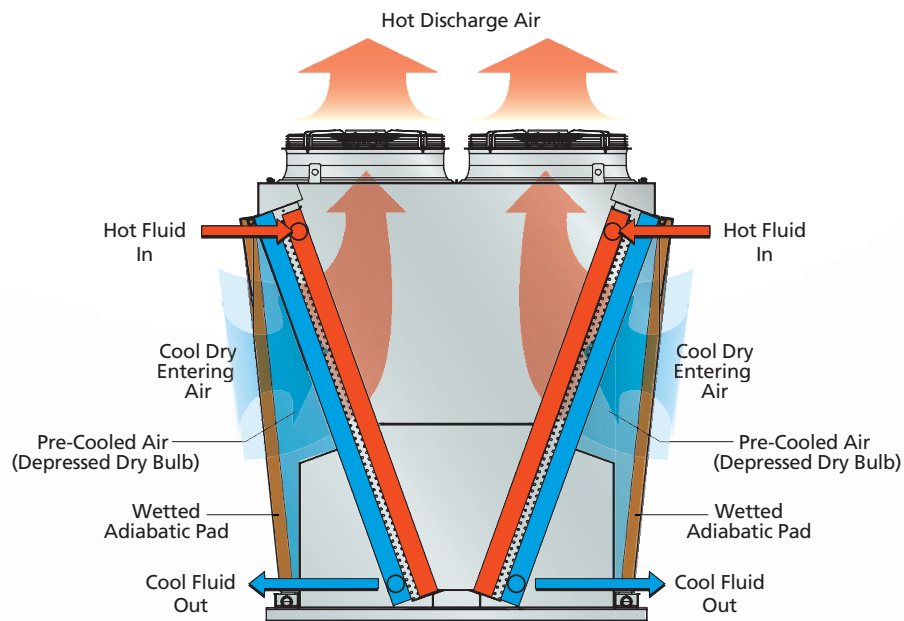

Advanced Coil Technology

EVAPCO has long been the industry innovator in heat exchanger coil technology starting in the early 1990's with the introduction of Thermal-Pak® coils which revolutionized the industry. Soon after, EVAPCO became the benchmark in industrial evaporator design, standardizing on stainless steel tubes and aluminum fins. The eco-Air Series coil design builds upon this past success. The coil tube diameter, geometry, and circuiting have been optimized through thousands of hours of theoretical modeling and laboratory testing. The result is optimal heat transfer efficiency with low airside pressure drop and low motor horsepower per ton.

Coil Design

Through the use of computational fluid dynamics (CFD) modeling software, finite element heat transfer analysis, and proprietary coil performance calculation methods, EVAPCO engineers have identified significant design elements to improve the finned coil performance. The extensive computer modeling has been refined and verified through coil performance evaluation in EVAPCO's state of the art research laboratories.

Superior Stainless Steel Technology

eco-Air Series dry coolers are constructed with high-grade Type 304L stainless steel tubing and aluminum fins as standard. The stainless steel tubing meets the requirements of ASME B31.5 piping code. The tubing is roll formed and continuously welded, annealed, and tested using an eddy current device.

The round tubing is fit into the aluminum fin plate and hydraulically expanded, this procedure provides more consistent contact between the tube and the fin plate than mechanical expansion. The entire coil is then pressure tested to 110% of design working pressure. Lastly, the coil is dried, evacuated, and charged with low-pressure nitrogen prior to shipment.

EVAPCO's stainless steel tubes are available in 5/8-inch OD. Coils are built in 6, 8, 10 or 12 FPI as standard using a full-collar aluminum fin. Multiple fin thicknesses are available to accommodate a range of industrial applications.

For applications where corrosion of the aluminum fin is a concern, EVAPCO offers pre-coated epoxy fin stock.



Benefits of eco-Air Series

Reduced Maintenance

Scaling, corrosion, and water born bacteria concerns are minimized or eliminated with dry and adiabatic cooling equipment. The eco-Air Series reduces the maintenance traditionally associated with fully evaporative systems.

The eco-Air Series adiabatic cooler is designed as a once through system, meaning it has no pump and no basin to hold water, reducing the time required for maintenance. Additionally, the adiabatic pads filter the air before reaching the coil, limiting the exposure of dirt and debris to the tube and fin heat transfer surface.

Both NEMA and EC motor options require zero routine maintenance. There are no bearings to grease, belts to adjust, or fans to pitch and balance.



Adiabatic Pad Drip Pan

Reduced or Eliminated Water Consumption

Compared to traditional evaporative systems, the eco-Air Series will either eliminate or dramatically reduce water consumption. Adiabatic models only use water when the ambient conditions and load require it. Reducing water consumption also reduces the ongoing expenses related with the cooling equipment such as purchasing, treating, and disposing of water.



Zero Maintenance Motors

When the eco-Air Series adiabatic models are used in conjunction with the EVAPCO controls package, water conservation is maximized based on proprietary PLC logic.

Factory Mounted and Wired Controls

The motors on the eco-Air Series are pre-wired at the factory to UL standards, reducing costs associated with field wiring. As standard, all units are wired to a common terminal box. Adding the EVAPCO controls package allows for both single point power supply and complete capacity control.

Installation Made Easy

All units are designed for lifting and staging in one piece.

Fork lift channels come standard on all eco-Air Series units up to 27 feet in length. On longer units, reference the eco-Air Series IO&M for lifting requirements from the fan deck lifting lugs.



Factory Wired Fan Motors



Factory Mounted Control Panel

V Coil Configuration - EC Motor

Engineering Data

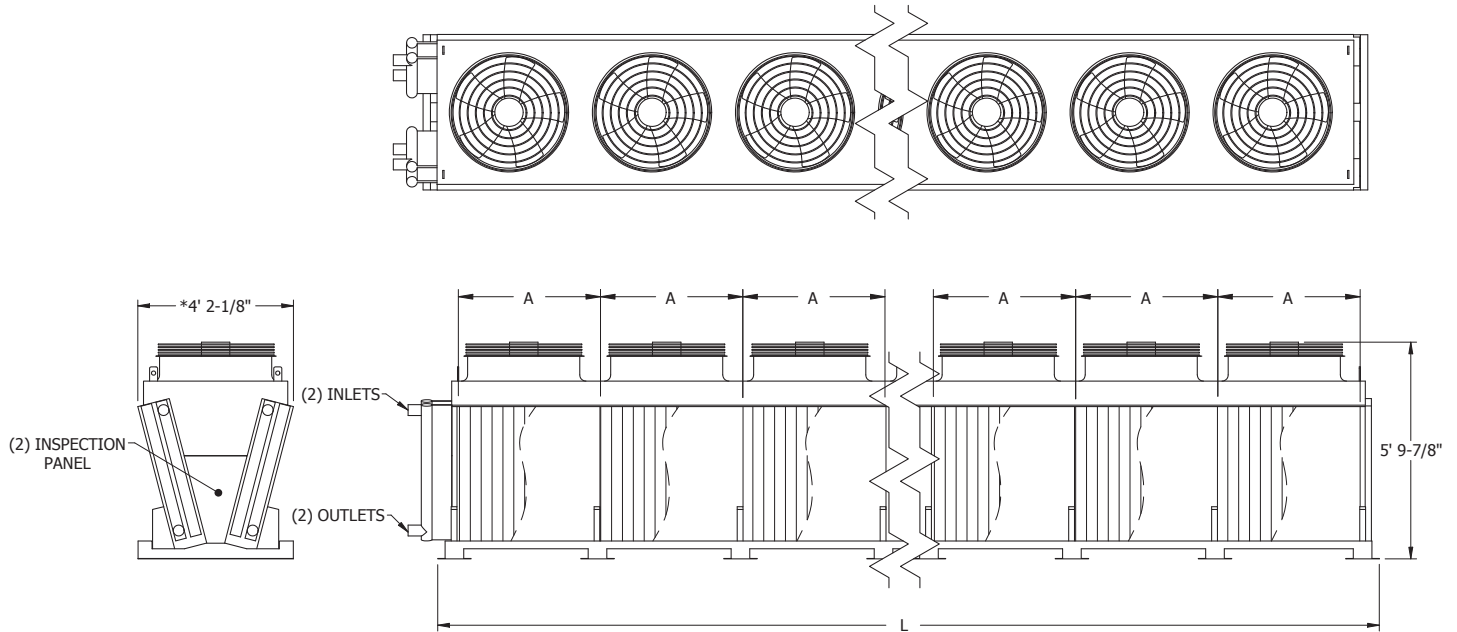

Single Fan, 4' Wide Models

Model Name	# Fans	Nominal Capacity (MBH)†	HP (kW)	Air Volume (cfm)	Unit Length (L)	Coil Volume (gal.)	Shipping Weight (lbs.)	Operating Weight (lbs.)
EAVWD91S1MJ	1	218	3.9 (2.9)	15300	5' 3-3/8"	34	1690	1970
EAVWD91S2MJ	2	430	7.8 (5.8)	30590	9' 6-5/8"	52	2830	3270
EAVWD91S3MJ	3	650	11.5 (8.6)	45890	13' 9-3/4"	71	4070	4660
EAVWD91S4MJ	4	853	15.4 (11.5)	61180	18' 0"	89	5350	6100
EAVWD91S5MJ	5	1075	19.3 (14.4)	76470	22' 4-1/8"	108	6630	7530
EAVWD91S6MJ	6	1295	23.2 (17.3)	91770	26' 7-3/8"	126	7860	8920
EAVWD91S7MJ	7	1488	27.1 (20.2)	107060	30' 10-1/2"	145	9030	10240
EAVWD91S8MJ	8	1712	30.8 (23.0)	122350	35' 1-3/4"	164	10270	11630
EAVWD91S9MJ	9	1935	34.7 (25.9)	137650	39' 4-7/8"	182	11490	13010
EAVWD91S0MA	10	2047	38.6 (28.8)	147570	39' 4-7/8"	182	11810	13330

Notes:

* Adiabatic width: 4' 8-1/4"

A: Two incremental fin lengths available: 3' 10-1/16" or 4' 3-3/16"

Dimensions are subject to change. Do not use for pre-fabrication.

† Nominal Capacity 110°F-100°F at 92°F dry bulb temp. Adiabatic = dry bulb 99°F

Adiabatic capacity: The adiabatic cooling effect and resulting depressed dry bulb entering the coil depends on the ambient dry bulb and associated relative humidity. Consult your sales representative, EVAPCO marketing, or Spectrum™ selection software for more information

V Coil Configuration - EC Motor

Engineering Data

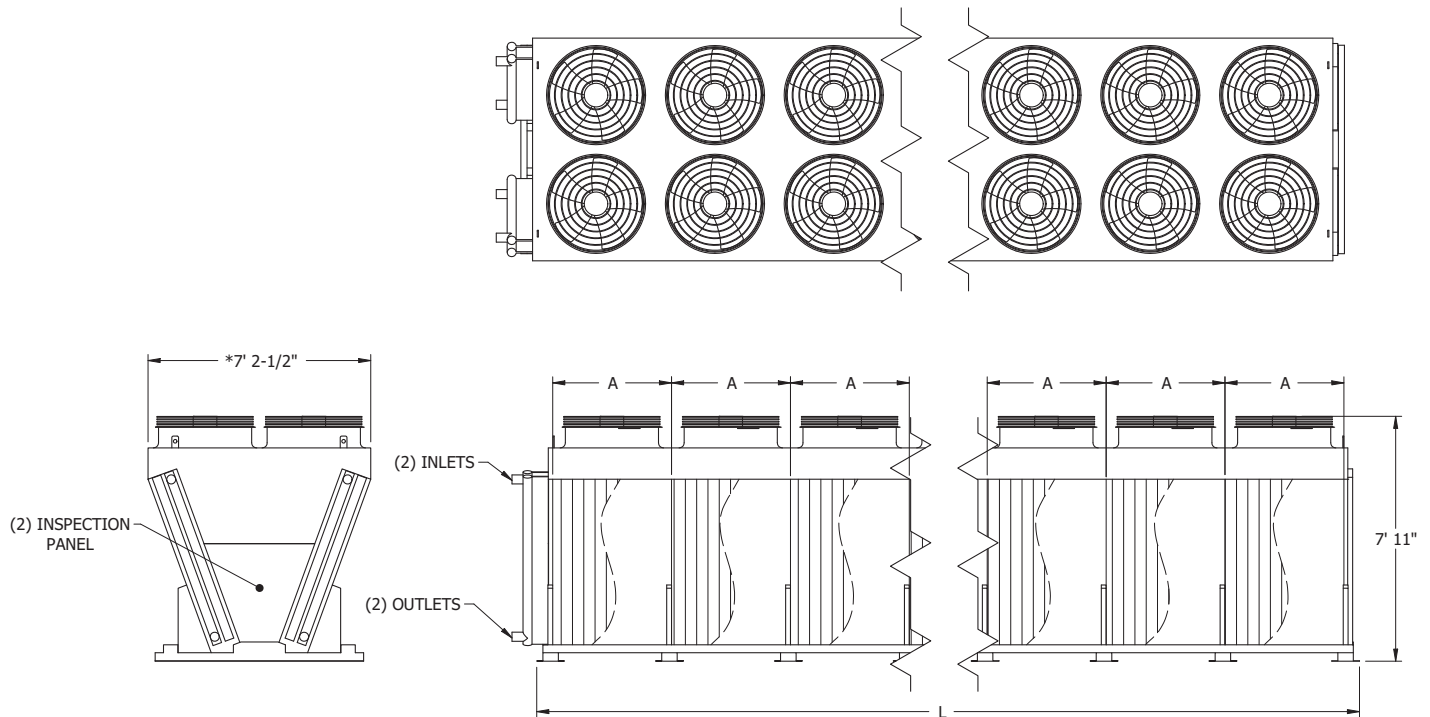

Twin Fan, 7' Wide Models

Model Name	# Fans	Nominal Capacity (MBH)†	HP (kW)	Air Volume (cfm)	Unit Length (L)	Coil Volume (gal.)	Shipping Weight (lbs.)	Operating Weight (lbs.)
EAVWD9102PJ	2	377	7.8 (5.8)	27510	5' 3-3/8"	51	2690	3120
EAVWD9104PJ	4	749	15.4 (11.5)	55010	9' 6-5/8"	80	4460	5130
EAVWD9106PJ	6	1134	23.2 (17.3)	82510	13' 9-3/4"	108	6410	7320
EAVWD9108PJ	8	1502	30.8 (23.0)	110010	18' 0"	137	8400	9540
EAVWD9110PJ	10	1868	38.6 (28.8)	137510	22' 4-1/8"	165	10390	11770
EAVWD9112PJ	12	2259	46.4 (34.6)	165020	26' 7-3/8"	194	12330	13950
EAVWD9114PJ	14	2595	54.0 (40.3)	192520	30' 10-1/2"	223	14130	15990
EAVWD9116PJ	16	2986	61.8 (46.1)	220020	35' 1-3/4"	251	16090	18190
EAVWD9118PJ	18	3377	69.4 (51.8)	247520	39' 4-7/8"	280	18010	20340
EAVWD9120PA	20	3487	77.2 (57.6)	257780	39' 4-7/8"	280	18570	20900

Notes:

* Adiabatic width: 7' 8-3/8"

A: Two incremental fin lengths available: 3' 10-1/16" or 4' 3-3/16"

Dimensions are subject to change. Do not use for pre-fabrication.

† Nominal Capacity 110°F-100°F at 92°F dry bulb temp. Adiabatic = dry bulb 99°F

Adiabatic capacity: The adiabatic cooling effect and resulting depressed dry bulb entering the coil depends on the ambient dry bulb and associated relative humidity. Consult your sales representative, EVAPCO marketing, or Spectrum™ selection software for more information

V Coil Configuration - EC Motor

Engineering Data

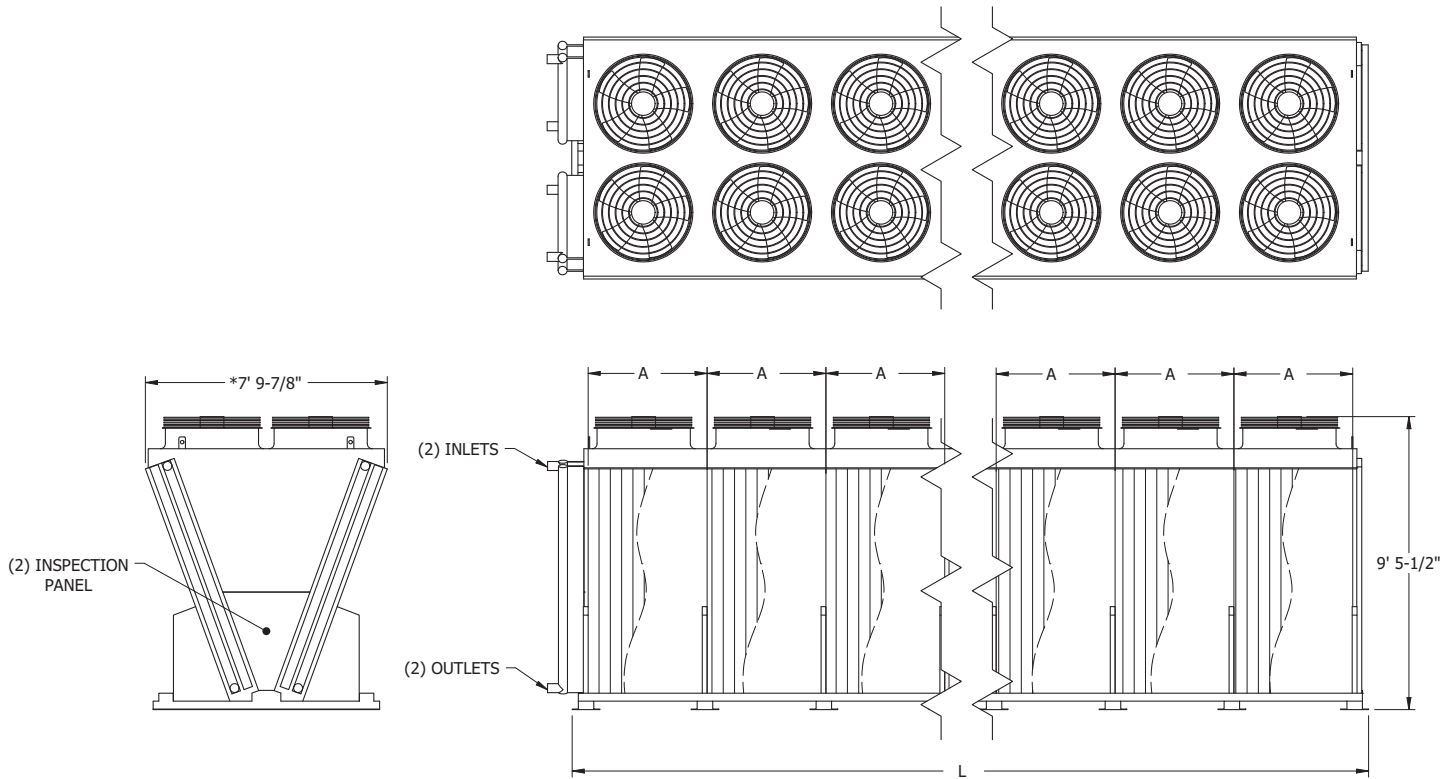

Twin Fan, 8' Wide Models

Model Name	# Fans	Nominal Capacity (MBH)†	HP (kW)	Air Volume (cfm)	Unit Length (L)	Coil Volume (gal.)	Shipping Weight (lbs.)	Operating Weight (lbs.)
EAVWD9102ZJ	2	442	7.8 (5.8)	30990	5' 3-3/8"	69	3140	3720
EAVWD9104ZJ	4	882	15.4 (11.5)	61980	9' 6-5/8"	107	5230	6130
EAVWD9106ZJ	6	1322	23.2 (17.3)	92960	13' 9-3/4"	146	7510	8730
EAVWD9108ZJ	8	1744	30.8 (23.0)	123950	18' 0"	185	9820	11360
EAVWD9110ZJ	10	2179	38.6 (28.8)	154940	22' 4-1/8"	223	12140	14000
EAVWD9112ZJ	12	2635	46.4 (34.6)	185920	26' 7-3/8"	262	14410	16600
EAVWD9114ZJ	14	3030	54.0 (40.3)	216910	30' 10-1/2"	300	16520	19030
EAVWD9116ZJ	16	3484	61.8 (46.1)	247900	35' 1-3/4"	339	18800	21630
EAVWD9118ZA	18	3940	69.4 (51.8)	269160	35' 6-7/8"	343	19520	22380
EAVWD9120ZA	20	4169	77.2 (57.6)	299060	39' 4-7/8"	378	21630	24780

Notes:

* Adiabatic width: 8' 3-7/8"

A: Two incremental fin lengths available: 3' 10-1/16" or 4' 3-3/16"

Dimensions are subject to change. Do not use for pre-fabrication.

† Nominal Capacity 110°F-100°F at 92°F dry bulb temp. Adiabatic = dry bulb 99°F

Adiabatic capacity: The adiabatic cooling effect and resulting depressed dry bulb entering the coil depends on the ambient dry bulb and associated relative humidity. Consult your sales representative, EVAPCO marketing, or Spectrum™ selection software for more information

V Coil Configuration - NEMA Motor

Engineering Data

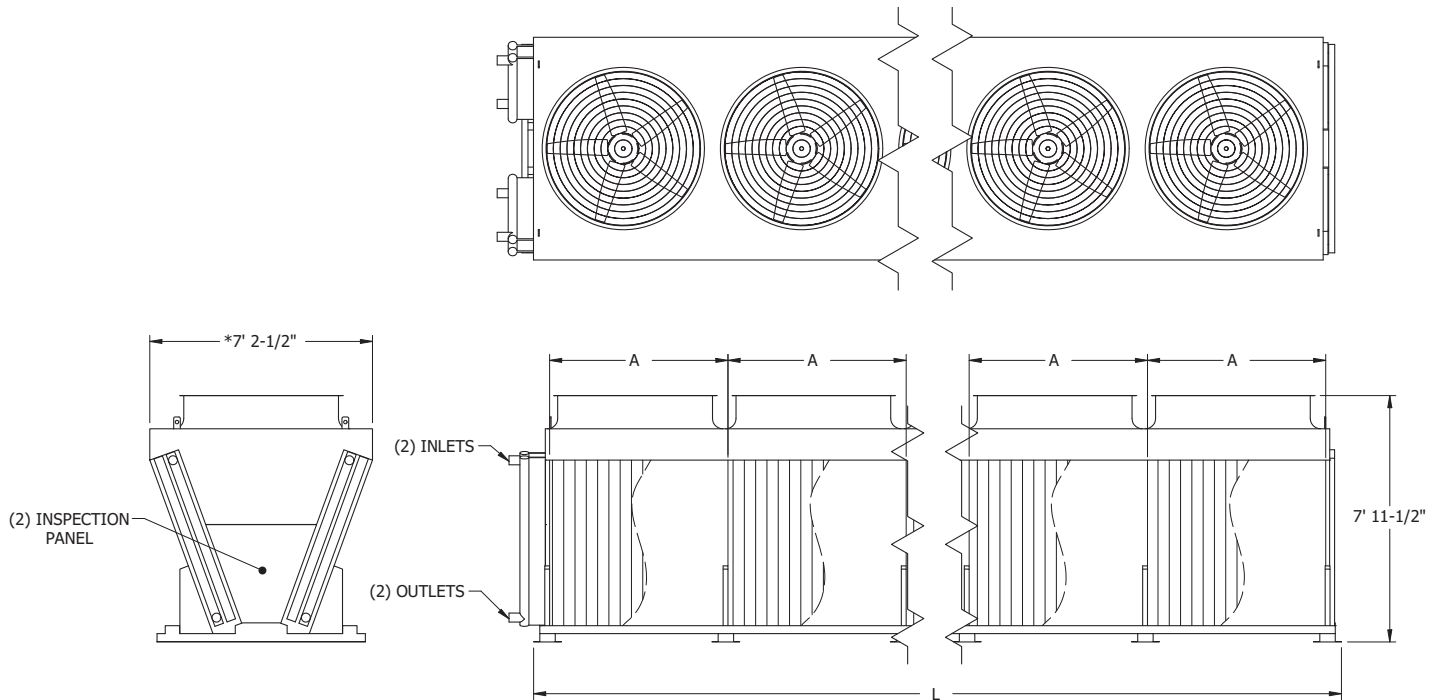

Single Fan, 7' Wide Models

Model Name	# Fans	Nominal Capacity (MBH)†	HP (kW)	Air Volume (cfm)	Unit Length (L)	Coil Volume (gal.)	Shipping Weight (lbs.)	Operating Weight (lbs.)
EAVWD15S1PI	1	611	10 (7.5)	44290	8' 8-3/8"	74	4150	4770
EAVWD15S2PI	2	1211	20 (15)	88570	16' 4-1/2"	125	7430	8480
EAVWD15S3PI	3	1826	30 (22.5)	132850	24' 5/8"	177	10780	12260
EAVWD15S4PI	4	2383	40 (30)	177130	31' 8-3/4"	228	13890	15800
EAVWD15S5PI	5	3008	50 (37.5)	221410	39' 4-7/8"	280	17200	19530
EAVWD15S6PK	6	3279	60 (45)	246630	39' 4-7/8"	280	17920	20250

Notes:

* Adiabatic width: 7' 8-3/8"

A: Three incremental fin lengths available: 5' 9-1/16", 6' 4-3/4" or 7' 8-1/8"

Dimensions are subject to change. Do not use for pre-fabrication.

† Nominal Capacity 110°F-100°F at 92°F dry bulb temp. Adiabatic = dry bulb 99°F

Adiabatic capacity: The adiabatic cooling effect and resulting depressed dry bulb entering the coil depends on the ambient dry bulb and associated relative humidity. Consult your sales representative, EVAPCO marketing, or Spectrum™ selection software for more information

V Coil Configuration - NEMA Motor

Engineering Data

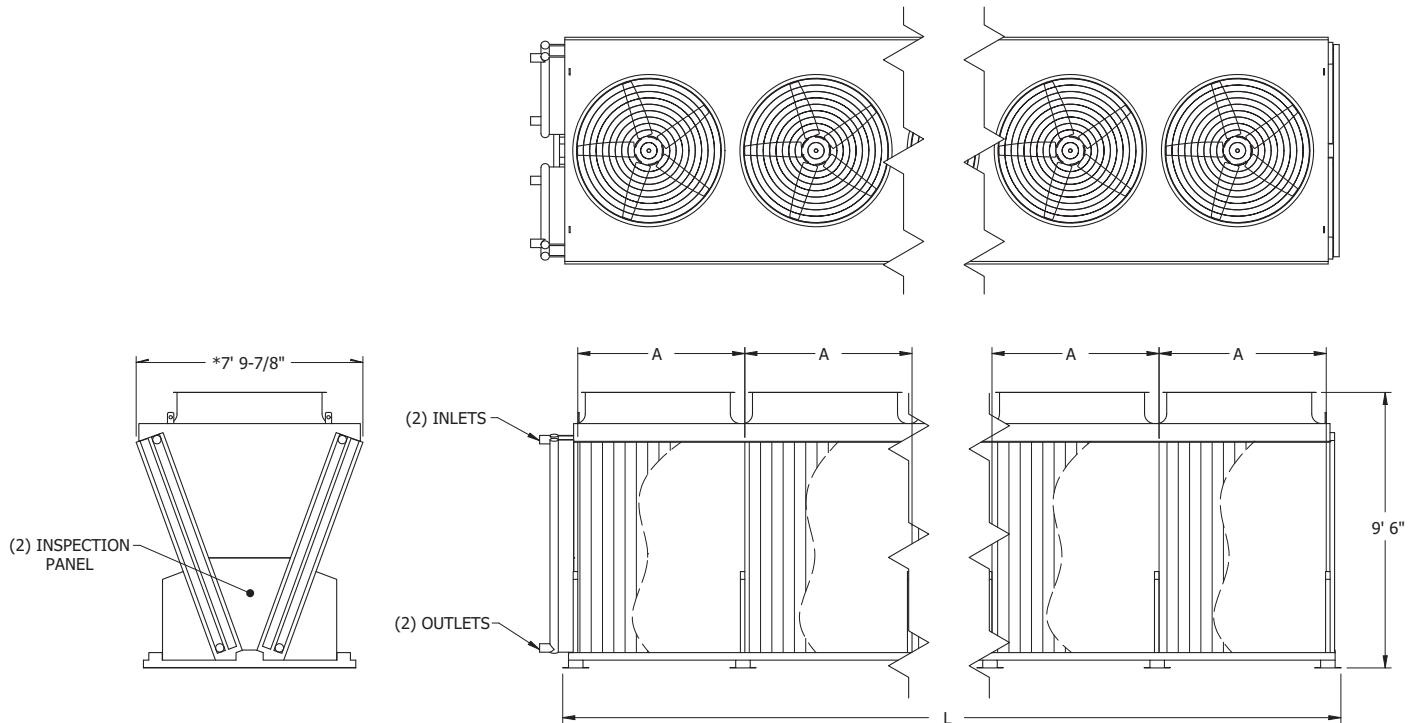

Single Fan, 8' Wide Models

Model Name	# Fans	Nominal Capacity (MBH)†	HP (kW)	Air Volume (cfm)	Unit Length (L)	Coil Volume (gal.)	Shipping Weight (lbs.)	Operating Weight (lbs.)
EAVWD15S1ZI	1	694	10 (7.5)	48710	8' 8-3/8"	100	4850	5690
EAVWD15S2ZI	2	1375	20 (15)	97410	16' 4-1/2"	169	8700	10110
EAVWD15S3ZI	3	2058	30 (22.5)	146110	24' 5/8"	239	12630	14620
EAVWD15S4ZI	4	2721	40 (30)	194810	31' 8-3/4"	308	16290	18860
EAVWD15S5ZI	5	3432	50 (37.5)	243520	39' 4-7/8"	378	20180	23330
EAVWD15S6ZK	6	3820	60 (45)	277130	39' 4-7/8"	378	20920	24070

Notes:

* Adiabatic width: 8' 3-7/8"

A: Two incremental fin lengths available: 5' 9-1/16", 6' 4-3/4" or 7' 8-1/8"

Dimensions are subject to change. Do not use for pre-fabrication.

† Nominal Capacity 110°F-100°F at 92°F dry bulb temp. Adiabatic = dry bulb 99°F

Adiabatic capacity: The adiabatic cooling effect and resulting depressed dry bulb entering the coil depends on the ambient dry bulb and associated relative humidity. Consult your sales representative, EVAPCO marketing, or Spectrum™ selection software for more information

Flat Coil Configuration - EC Motor

Engineering Data

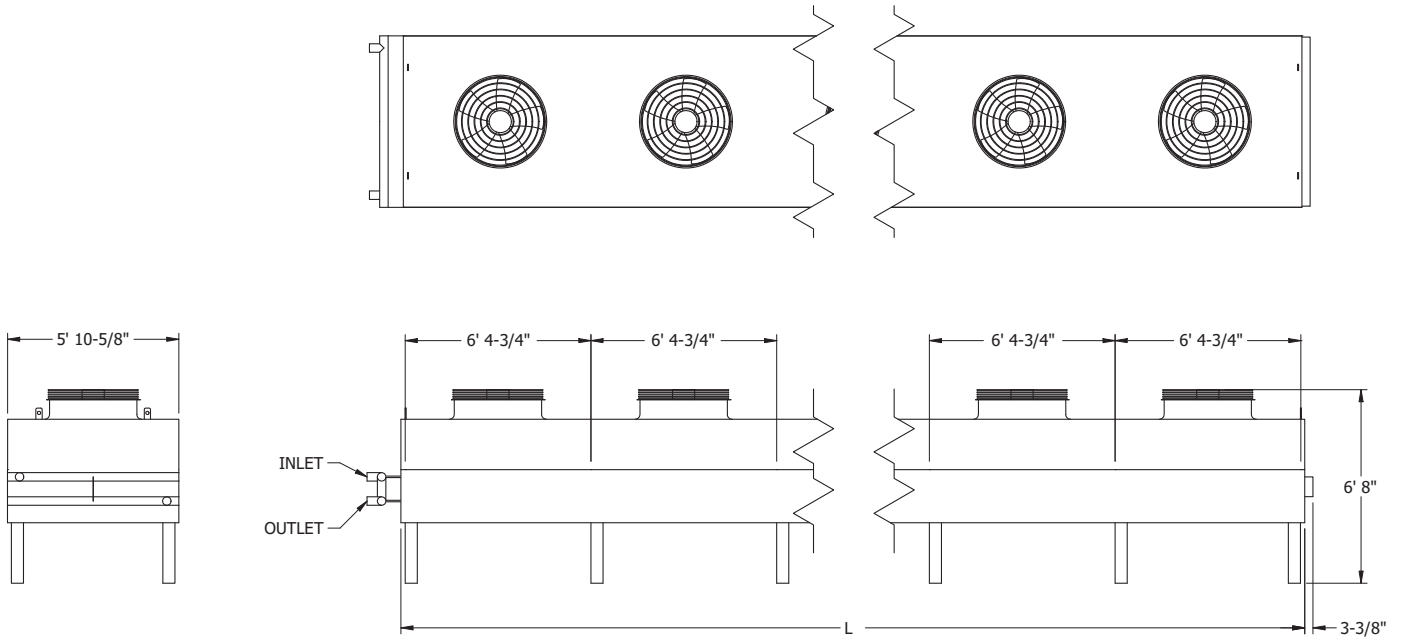

Single Fan, 6' Wide Models

Model Name	# Fans	Nominal Capacity (MBH) [†]	HP (kW)	Air Volume (cfm)	Unit Length (L)	Coil Volume (gal.)	Shipping Weight (lbs.)	Operating Weight (lbs.)
EAFFWD91S1WK	1	230	3.9 (2.9)	16070	6' 8-1/4"	33	1840	2120
EAFFWD91S2WK	2	463	7.8 (5.8)	32140	13' 0"	54	3180	3640
EAFFWD91S3WK	3	693	11.5 (8.6)	48210	19' 5-3/4"	76	4680	5310
EAFFWD91S4WK	4	922	15.4 (11.5)	64280	25' 10-1/2"	97	5930	6740
EAFFWD91S5WK	5	1140	19.3 (14.4)	80350	32' 3-1/4"	118	7210	8200
EAFFWD91S6WK	6	1379	23.2 (17.3)	96420	38' 8"	140	8540	9710

Notes:

Dimensions are subject to change. Do not use for pre-fabrication.

[†] Nominal Capacity based on 110°F-100°F at 92°F dry bulb temperature.

Flat Coil Configuration - EC Motor

Engineering Data

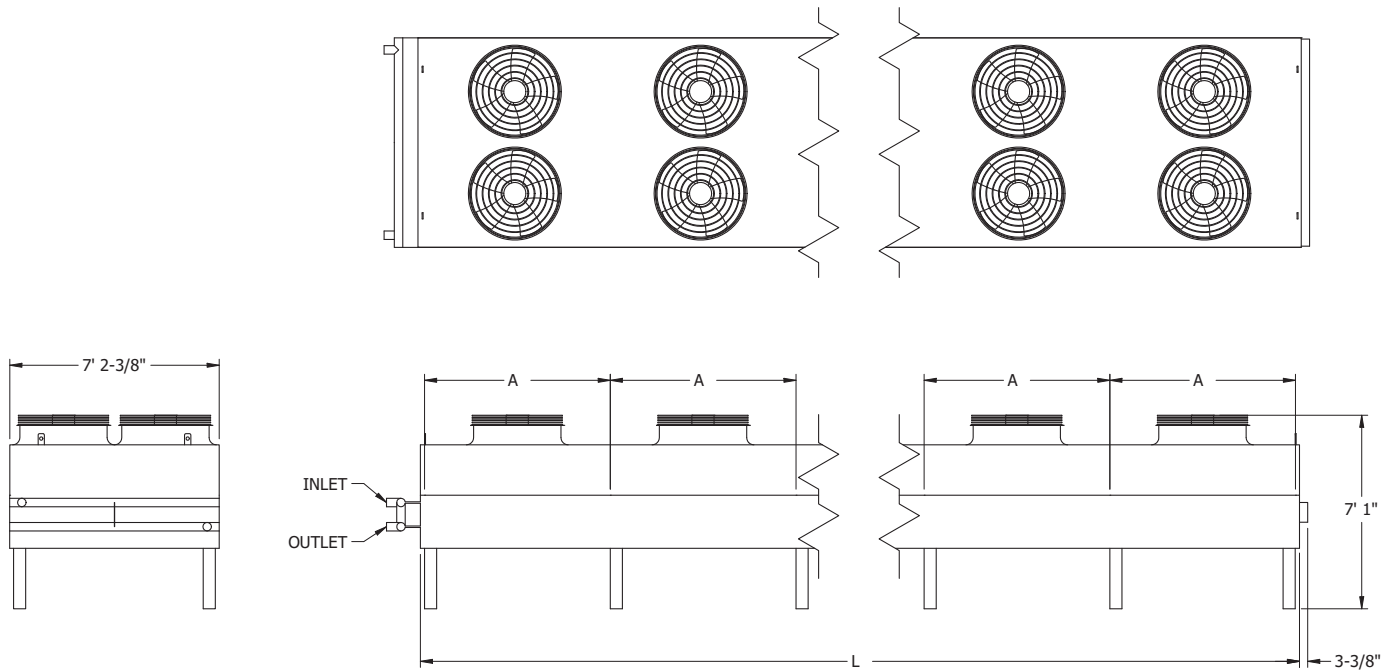

Twin Fan, 7' Wide Models

Model Name	# Fans	Nominal Capacity (MBH) [†]	HP (kW)	Air Volume (cfm)	Unit Length (L)	Coil Volume (gal.)	Shipping Weight (lbs.)	Operating Weight (lbs.)
EAFWD9102PI	2	394	3.9 (2.9)	28560	7' 11-1/2"	44	2490	2860
EAFWD9104PI	4	782	7.8 (5.8)	57110	15' 7-5/8"	75	4480	5110
EAFWD9106PI	6	1177	11.5 (8.6)	85660	23' 3-3/4"	106	6480	7370
EAFWD9108PI	8	1554	15.4 (11.5)	114210	30' 11-7/8"	137	8300	9450
EAFWD9110PI	10	1962	19.3 (14.4)	142830	38' 8 "	168	10300	11700
EAFWD9112PK	12	2092	23.2 (17.3)	154700	38' 8 "	168	10540	11940

Notes:

A: Two incremental fin lengths available: 6' 4-3/4" or 7' 8-1/8"

Dimensions are subject to change. Do not use for pre-fabrication.

[†] Nominal Capacity based on 110°F-100°F at 92°F dry bulb temperature.

Flat Coil Configuration - EC Motor

Engineering Data

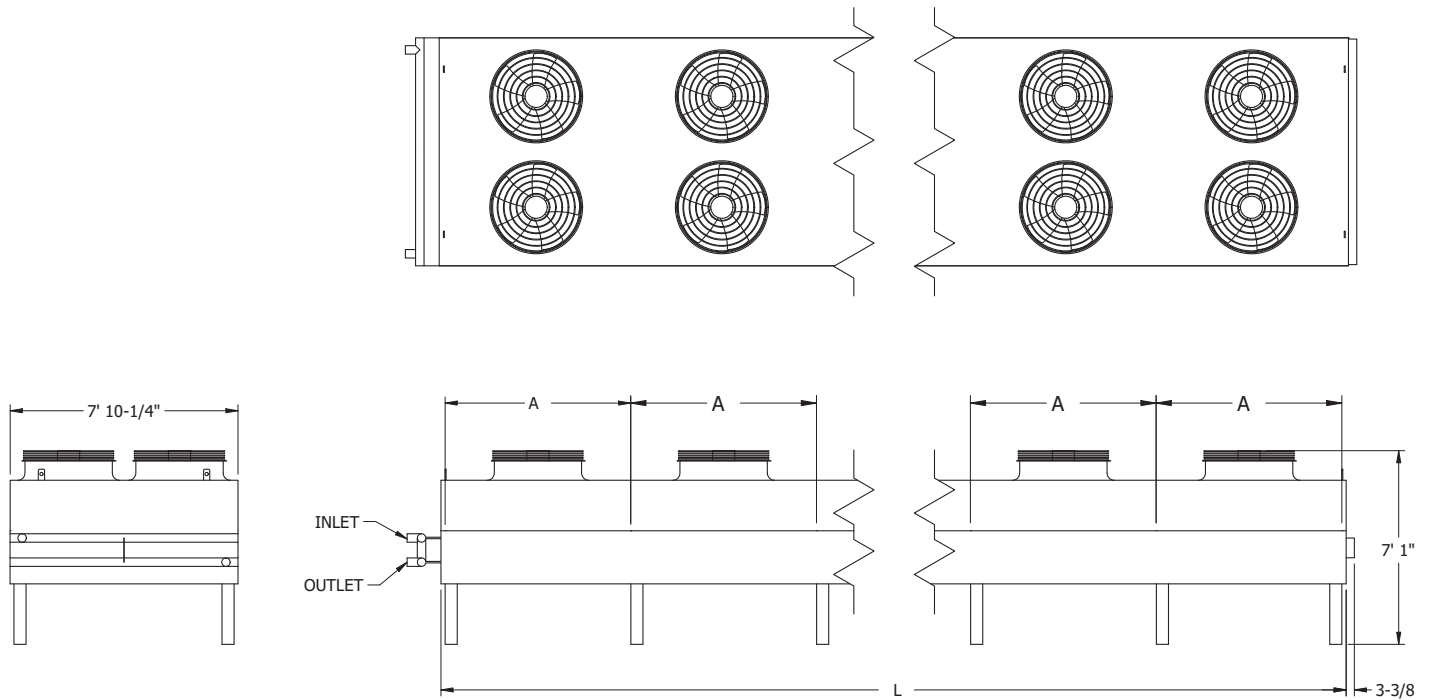

Twin Fan, 8' Wide Models

Model Name	# Fans	Nominal Capacity (MBH) [†]	HP (kW)	Air Volume (cfm)	Unit Length (L)	Coil Volume (gal.)	Shipping Weight (lbs.)	Operating Weight (lbs.)
EAFWD9102ZI	2	419	3.9 (2.9)	29910	7' 11-1/2"	50	2680	3100
EAFWD9104ZI	4	835	7.8 (5.8)	59820	15' 7-5/8"	85	4840	5550
EAFWD9106ZI	6	1249	11.5 (8.6)	89720	23' 3-3/4"	119	7000	8000
EAFWD9108ZI	8	1652	15.4 (11.5)	119630	30' 11-7/8"	154	8980	10270
EAFWD9110ZI	10	2085	19.3 (14.4)	149530	38' 8 "	189	11140	12720
EAFWD9112ZK	12	2269	23.2 (17.3)	166130	38' 8 "	189	11390	12970

Notes:

A: Two incremental fin lengths available: 6' 4-3/4" or 7' 8-1/8"

Dimensions are subject to change. Do not use for pre-fabrication.

[†] Nominal Capacity based on 110°F-100°F at 92°F dry bulb temperature.

Flat Coil Configuration - NEMA Motor

Engineering Data

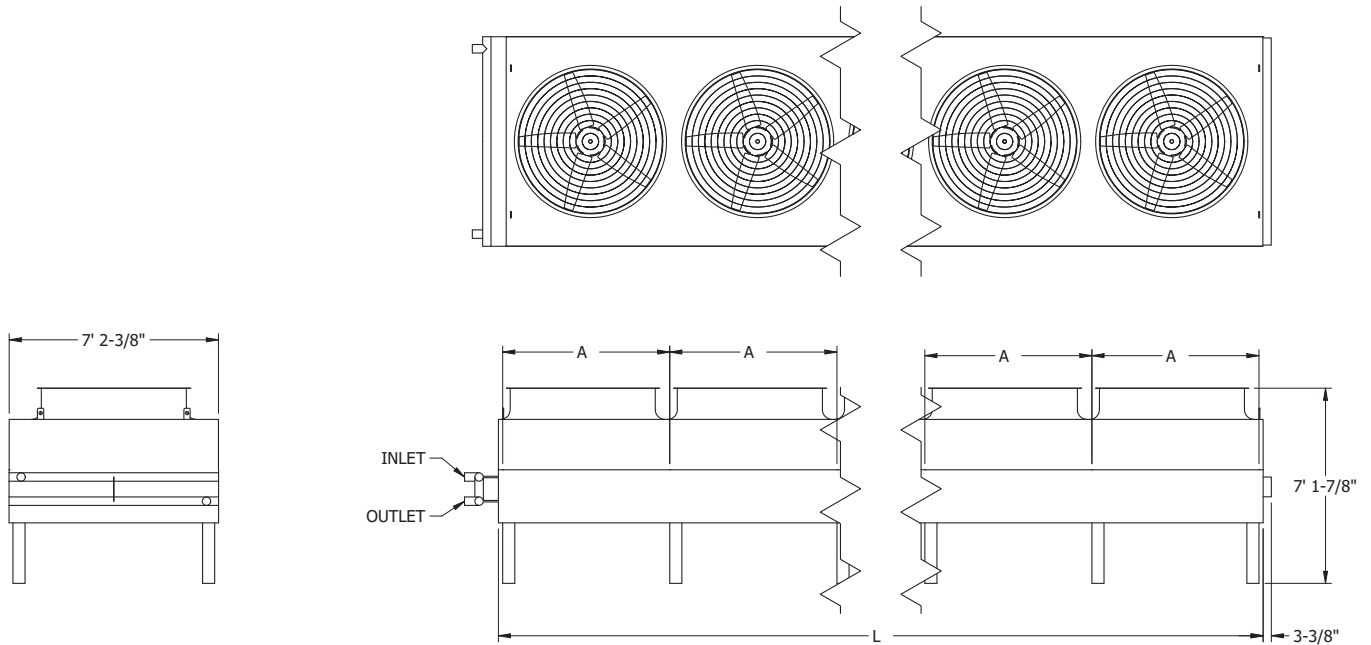

Single Fan, 7' Wide Models

Model Name	# Fans	Nominal Capacity (MBH)†	HP (kW)	Air Volume (cfm)	Unit Length (L)	Coil Volume (gal.)	Shipping Weight (lbs.)	Operating Weight (lbs.)
EAFWD15S1PI	1	446	10 (7.5)	34540	7' 11-1/2"	44	2810	3180
EAFWD15S2PI	2	883	20 (15)	69080	15' 7-5/8"	75	5120	5750
EAFWD15S3PI	3	1329	30 (22.5)	103620	23' 3-3/4"	106	7440	8330
EAFWD15S4PI	4	1755	40 (30)	138150	30' 11-7/8"	137	9590	10740
EAFWD15S5PI	5	2216	50 (37.5)	172690	38' 8 "	168	11900	13300
EAFWD15S6PK	6	2327	60 (45)	184420	38' 8 "	168	12400	13800

Notes:

A: Three incremental fin lengths available: 5' 9-1/16", 6' 4-3/4" or 7' 8-1/8"

Dimensions are subject to change. Do not use for pre-fabrication.

† Nominal Capacity based on 110°F-100°F at 92°F dry bulb temperature.

Flat Coil Configuration - NEMA Motor

Engineering Data

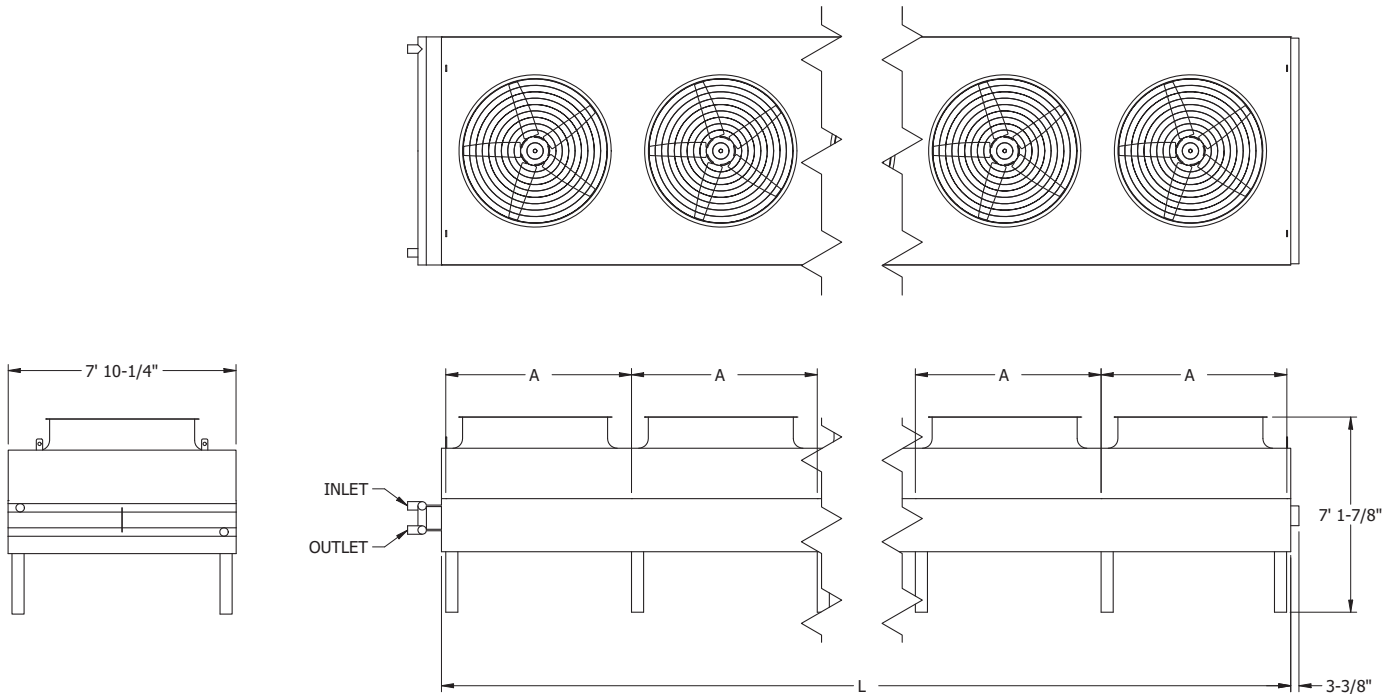

Single Fan, 8' Wide Models

Model Name	# Fans	Nominal Capacity (MBH) [†]	HP (kW)	Air Volume (cfm)	Unit Length (L)	Coil Volume (gal.)	Shipping Weight (lbs.)	Operating Weight (lbs.)
EAFWD15S1ZI	1	482	10 (7.5)	36950	7' 11-1/2"	50	3010	3430
EAFWD15S2ZI	2	951	20 (15)	73900	15' 7-5/8"	85	5490	6200
EAFWD15S3ZI	3	1440	30 (22.5)	110840	23' 3-3/4"	119	7970	8970
EAFWD15S4ZI	4	1901	40 (30)	147790	30' 11-7/8"	154	10260	11550
EAFWD15S5ZI	5	2401	50 (37.5)	184740	38' 8 "	189	12740	14320
EAFWD15S6ZK	6	2539	60 (45)	199060	38' 8 "	189	13250	14830

Notes:

A: Three incremental fin lengths available: 5' 9-1/16", 6' 4-3/4" or 7' 8-1/8"

Dimensions are subject to change.

† Nominal Capacity based on 110°F-100°F at 92°F dry bulb temperature.

Wiring and Control Options

Factory wiring and control options are available for both dry and adiabatic coolers. All wiring follows UL recognized standards. Many eco-Air Series configurations allow for single point power and factory mounted components. Please consult your sales representative or EVAPCO Marketing for job specific details.

Common Terminal Box (standard) - All motors wired to a common terminal box located on the end panel opposite coil connections. Factory wiring and design complies with UL Recognized Standards.



Individual Motor Disconnect Switches (optional) - Mounted at each fan motor to give the user the ability to isolate individual motor power feeds.



Wiring and Control Options

EVAPCO Control Package – Operating sequence and fan speed control based on real time heat loads and ambient conditions.



- EVAPCO PLC Controller
- Supervisory control system integration
- Fan speed control
 - EC Motor Option: Modbus control of EC fan
 - NEMA Motor Option: Packaged VFD fan speed control with bypass switch
- UL Listed
- NEMA 3R Rated
- Thermal overload and short circuit protection of each motor
- Operate and fault indicator lights on outside of panel
- Fluid Temperature Sensor (shipped loose)
- Ambient Temperature Sensor
- Rain/Sun Protection Hood (optional)
- Solenoid control of adiabatic pre-cooling system (if equipped)

Solenoid Control of Adiabatic Pre-cooling System (if equipped)

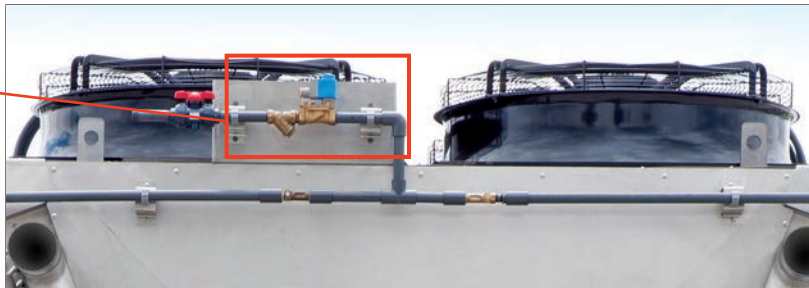

Adiabatic water supply solenoid valve arrangement

The EVAPCO Control Package is factory mounted and wired when configuration and shipping limitations allow.



UL (cUL) Compliance

All Components are UL Recognized



The entire unit is UL Listed when provided with factory mounted and wired EVAPCO Control Package.



Structural Steel Support

eco-Air Series Supporting Steel Dimensions	
V Models	Base Width (W)
4' Wide	4' 2"
7' Wide	7' 2-1/2"
8' Wide	7' 3-3/4"
F Models	Base Width (W)
6' Wide	5' 7-5/16"
7' Wide	6' 11-1/8"
8' Wide	7' 7"

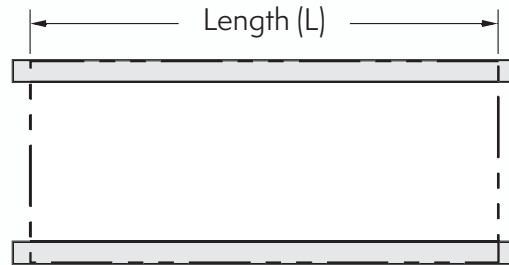
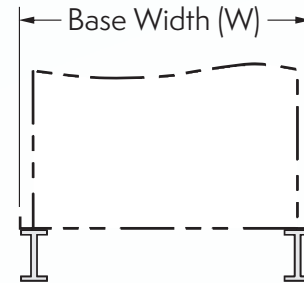

Length as shown on "unit length range (L)" in catalog table

1. These are suggested arrangements for preliminary layout purposes. Consult your EVAPCO representative for factory certified steel support drawings.
2. The recommended support for the eco-Air Series coolers is structural I-beams running the entire length of the unit. Mounting holes, 3/4" in diameter are provided for bolting to the structural steel.
3. Beams should be sized in accordance with accepted structural practices. Maximum deflection of beam under unit to be 1/360 of the unit length, not to exceed 1/2".
5. Beams should be level before setting the unit in place. Do not level the unit by shimming between it and the I-beams.
6. Support beams and Anchor bolts are to be furnished by others.
7. Dimensions, weights and data are subject to change without notice. Refer to the factory certified drawings for exact dimensions.

EVAPCO Technical Support Services

EVAPCO Representatives

Your EVAPCO representative is the local expert you can count on to help you with all your HVAC and industrial process needs—from getting quotes, to answering questions, to helping you manage your projects and orders. Find your local representative, by visiting evapco.com now.

SPECTRUM™ by EVAPCO

SPECTRUM™ is a new industry leading computer selection program that makes it easy for you to find and optimize the right EVAPCO solutions for every project. Evaluate thermal performance, layout, and energy requirements across units; analyze optional equipment features; and generate complete specifications and unit drawings—all within a friendly and intuitive format. Contact your EVAPCO representative to access SPECTRUM™ now.



evapco.com

Bookmark evapco.com for the latest and most complete product information. The website contains a multitude of information and resources including:

- Unit certified drawings
- Steel support drawings
- Scaled isometric views in CAD
- 3-D models in Revit
- Product catalogs
- Rigging instructions
- Operation and maintenance instructions
- White papers
- Videos
- Logo apparel and merchandise

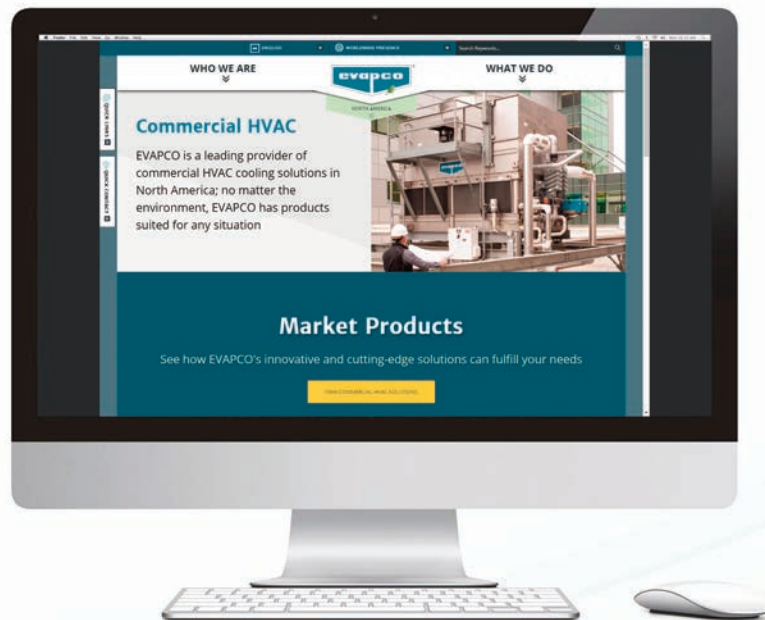



WORLDWIDE MANUFACTURING FACILITIES



- World Headquarters/ Research and Development Center
- EVAPCO Facilities

EVAPCO, Inc. — World Headquarters & Research / Development Center

P.O. Box 1300 • Westminster, MD 21158 USA
410-756-2600 p • marketing@evapco.com • evapco.com

North America

EVAPCO, Inc.
World Headquarters
P.O. Box 1300
Westminster, MD 21158 USA
410-756-2600 p | 410-756-6450 f
E-mail: marketing@evapco.com

EVAPCO East
5151 Allendale Lane
Taneytown, MD 21787 USA
410-756-2600 p | 410-756-6450 f
E-mail: marketing@evapco.com

EVAPCO Midwest
1723 York Road
Greenup, IL 62428 USA
217-923-3431 p | 217-923-3300 f
E-mail: evapcomw@evapcomw.com

EVAPCO West
1900 West Almond Avenue
Madera, CA 93637 USA
559-673-2207 p | 559-673-2378 f
E-mail: contact@evapcwest.com

EVAPCO Iowa
925 Quality Drive
Lake View, IA 51450 USA
712-657-3223 p | 712-657-3226 f

EVAPCO Iowa Sales & Engineering
215 1st Street, NE
P.O. Box 88
Medford, MN 55049 USA
507-446-8005 p | 507-446-8239 f
E-mail: evapconn@evapconn.com

EVAPCO Newton
701 East Jourdan Street
Newton, IL 62448 USA
618-783-3433 p | 618-783-3499 f
E-mail: evapcomw@evapcomw.com

EVAPCOLD
521 Evapco Drive
Greenup, IL 62428 USA
217-923-3431 p
E-mail: evapcomw@evapcomw.com

EVAPCO-BLCT Dry Cooling, Inc.
1011 US Highway 22 West
Bridgewater, New Jersey 08807 USA
908-379-2665 p
E-mail: info@evapco-blct.com

Refrigeration Valves & Systems Corporation
A wholly owned subsidiary of EVAPCO, Inc.
1520 Crosswind Dr.
Bryan, TX 77808 USA
979-778-0095 p | 979-778-0030 f
E-mail: rvs@rvscorp.com

EvapTech, Inc.
A wholly owned subsidiary of EVAPCO, Inc.
8331 Nieman Road
Lenexa, KS 66214 USA
913-322-5165 p | 913-322-5166 f
E-mail: marketing@evaptech.com

Tower Components, Inc.
A wholly owned subsidiary of EVAPCO, Inc.
5960 US HWY 64E
Ramseur, NC 27316
336-824-2102 p | 336-824-2190 f
E-mail: mail@towercomponentsinc.com

South America

EVAPCO Brasil
Equipamentos Industriais Ltda.
Al. Vênus, 151 – CEP: 13347-659
Indaiatuba – São Paulo – Brasil
(55) 11-5681 2000 p
E-mail: vendas@evapco.com.br

Europe

EVAPCO Europe BVBA
European Headquarters
Heersteveldweg 19
Industrieterrein Oost
3700 Tongeren, Belgium
Phone: (32) 12-395029
Fax: (32) 12-238527
E-mail: evapco.europe@evapco.be

EVAPCO Europe, S.r.l.
Via Ciro Menotti 10
I-20017 Passirana di Rho
Milan, Italy
(39) 02-939-9041 p | (39) 02-935-00840 f
E-mail: evapcoeuropa@evapco.it

EVAPCO Europe, S.r.l.
Via Dosso 2
23020 Piateda
Sondrio, Italy

EVAPCO Europe GmbH
Insterburger Straße 18
D-40670 Meerbusch, Germany
(49) 2159-695618 p | (49) 2159-695611 f
E-mail: info@evapco.de

EVAPCO Air Solutions
Knøsgårdvej 115
DK-9440 Aabybro Denmark
(45) 9824 4999 p | (45) 9824 4990 f
E-mail: info@evapco.dk

EVAPCO Air Solutions GmbH
Berenbosteler Str. 76 A
30823 Garbsen, Germany
(49) 5137 93875-0 p | (49) 5137 93875-20 f
info@evapcoas.de

Evap Egypt Engineering Industries Co.
A licensed manufacturer of EVAPCO, Inc.
5 El Nasr Road
Nasr City, Cairo, Egypt
2 02 24022866 / 2 02 24044997 p
2 02 24044667 / 2 02 24044668 f
E-mail: Primacool@link.net / Shady@primacool.net

EVAPCO S.A. (Pty.) Ltd.
A licensed manufacturer of EVAPCO, Inc.
18 Quality Road
Isando 1600
Republic of South Africa
(27) 11-392-6630 p | (27) 11-392-6615 f
E-mail: evapco@evapco.co.za

Asia/Pacific

EVAPCO Asia/Pacific Headquarters
1159 Luoning Rd. Baoshan Industrial Zone
Shanghai 200949, P.R. China
Phone: (86) 21-6687-7786
Fax: (86) 21-6687-7008
E-mail: marketing@evapcochina.com

EVAPCO (Shanghai) Refrigeration Equipment Co., Ltd.
1159 Luoning Rd., Baoshan Industrial Zone
Shanghai 200949, P.R. China
(86) 21-6687-7786 p | (86) 21-6687-7008 f
E-mail: marketing@evapcochina.com

Beijing EVAPCO Refrigeration Equipment Co., Ltd.
No. 13 Yanxi Avenue, Yanqi Development Zone
Huai Rou County
Beijing, P.R. China
Postal Code: 101407
(86) 10 6166-7238 p | (86) 10 6166-7395 f
E-mail: evapcobj@evapcochina.com

EVAPCO Australia (Pty.) Ltd.
34-42 Melbourne Road
P.O. Box 436
Riverstone, N.S.W. 2765, Australia
(61) 2 9627-3322 p | (61) 2 9627-1715 f
E-mail: sales@evapco.com.au

EVAPCO Composites Sdn. Bhd
No. 70 (Lot 1289) Jalan Industri 2/3
Rawang Integrated Industrial Park
48000 Rawang, Selangor, Malaysia
60 3 6092-2209 p | 60 3 6092-2210 f

EvapTech Asia Pacific Sdn. Bhd
A wholly owned subsidiary of EvapTech, Inc.
B-6-1, IOI Boulevard
Jalan Kenari 5, Bandar Puchong Jaya
47170 Puchong, Selangor, Malaysia
(60-3) 8070-7255 p | (60-3) 8070-5731 f
E-mail: marketing-ap@evaptech.com

